



# ***The Global Nuclear Energy Partnership – The Technology Demonstration Program***

***Brent Dixon  
Idaho National Laboratory***

***July 21, 2006***

# *What is GNEP?*



The Global Nuclear Energy partnership is a comprehensive strategy to:

- Increase U.S. and global energy security
- Encourage clean development around the world & improve the environment
- Reduce the risk of nuclear proliferation

# *Key Elements*



- Expand Nuclear Energy
- Recycle Nuclear Fuel & Reduce Nuclear Waste
- Enhance Nonproliferation Arrangements

# ***GNEP Strategy***



- Build a new generation of nuclear power plants in the United States.
- Open the federal geologic repository
- Develop and deploy new nuclear recycling technologies.
- Design Advance Burner Reactors that would produce energy from recycled nuclear fuel.
- Establish a fuel services program that would allow developing nations to acquire and use nuclear energy economically while minimizing the risk of nuclear proliferation.
- Develop and construct small scale reactors designed for the needs of developing countries.
- Improve nuclear safeguards to enhance the proliferation-resistance and safety of expanded nuclear power.

# Why Recycle?



## ■ *National Motivations:*

- *Optimal use of repository (ies)*
- *Near-term management of spent nuclear fuel*
- *Recovery of energy value in SNF (natural resource utilization)*

## ■ *International Motivations:*

- *Global nuclear-materials management options*
- *Guidance for policy decisions on governance regimes*
- *Leadership in defining advanced systems for proliferation resistance*

# Used Nuclear Fuel (less cladding)

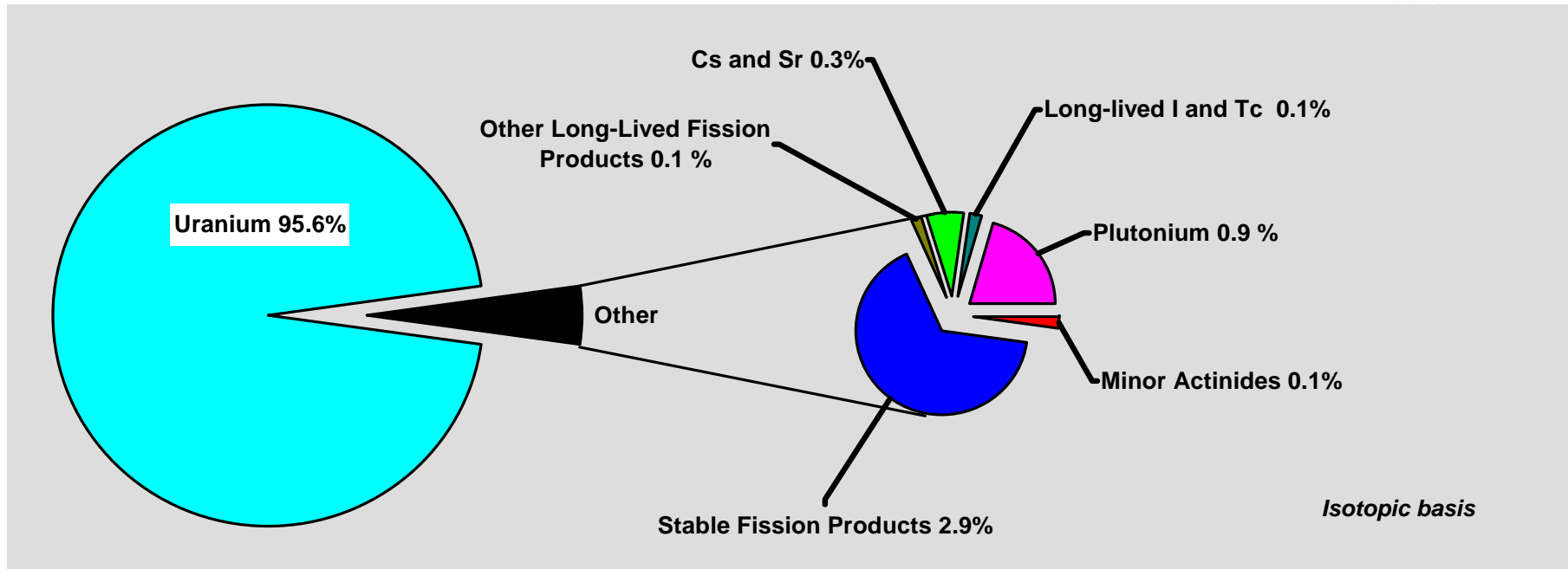

# Potential Repository Needs



Nuclear Futures		Existing License Completion	Extended License Completion	Continuing Level Energy Generation	Continuing Market Share Generation	Growing Market Share Generation
Cumulative discharged fuel in the year 2100 (metric ton)		100,000	120,000	250,000	600,000	1,400,000
Existing Reactors Only			↔	Existing and New Reactors		
Fuel Management Approach		Number of Repositories Needed at 70,000 Metric Ton Each				
No Recycle	Once-Through	2	2	4	9	20
	Once-Through, High Burnup Fuels	2	2	3	7	17
Reprocess & Recycle	Limited Recycle, High Burnup Fuels	Recycle not Recommended		2	5	10
	Transitional and Sustained Recycle			1	1	1

04-GA50634-20

# Repository Benefits Radiotoxicity for Limited/Continuous Recycle

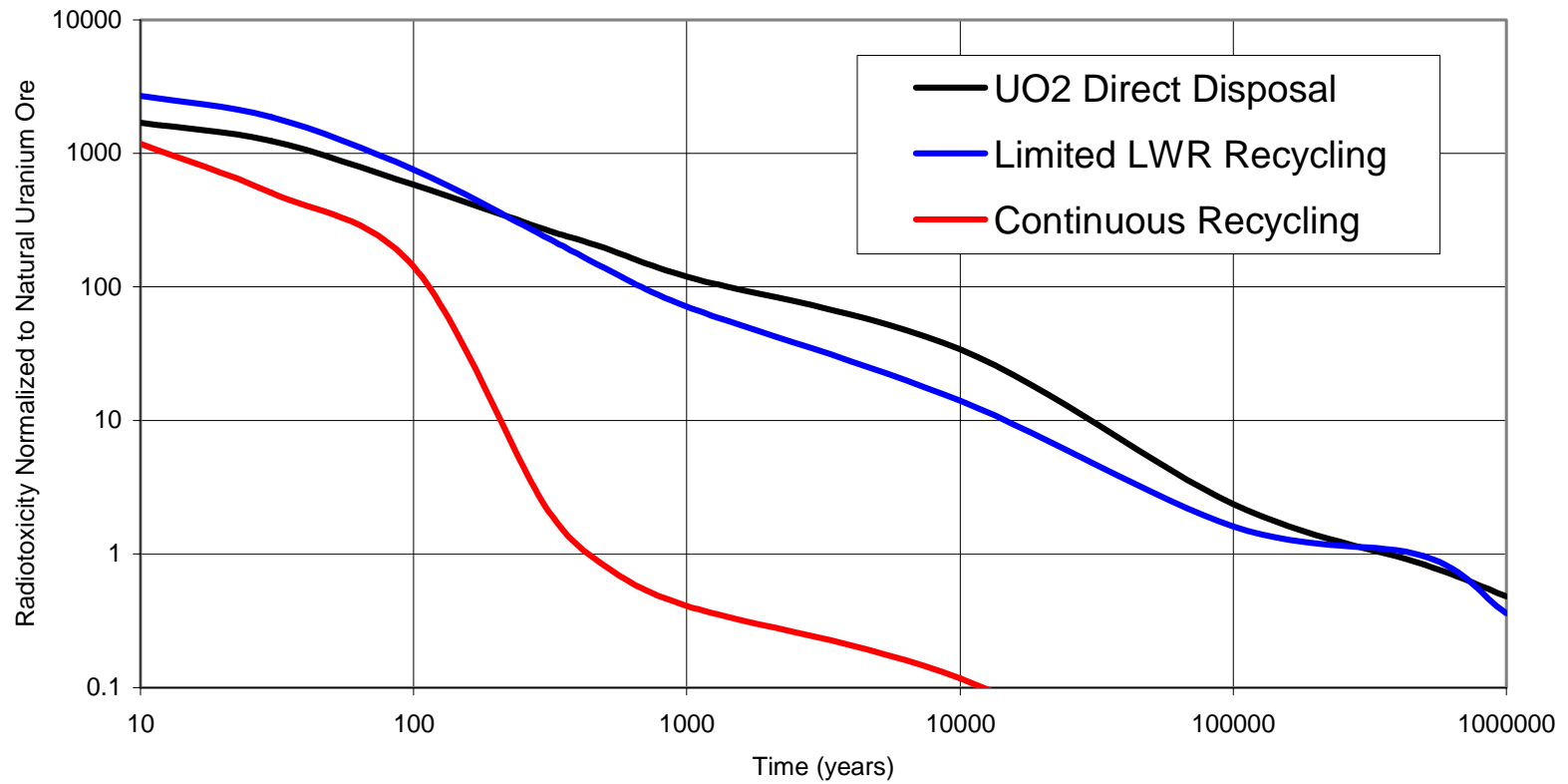



# Plutonium Management

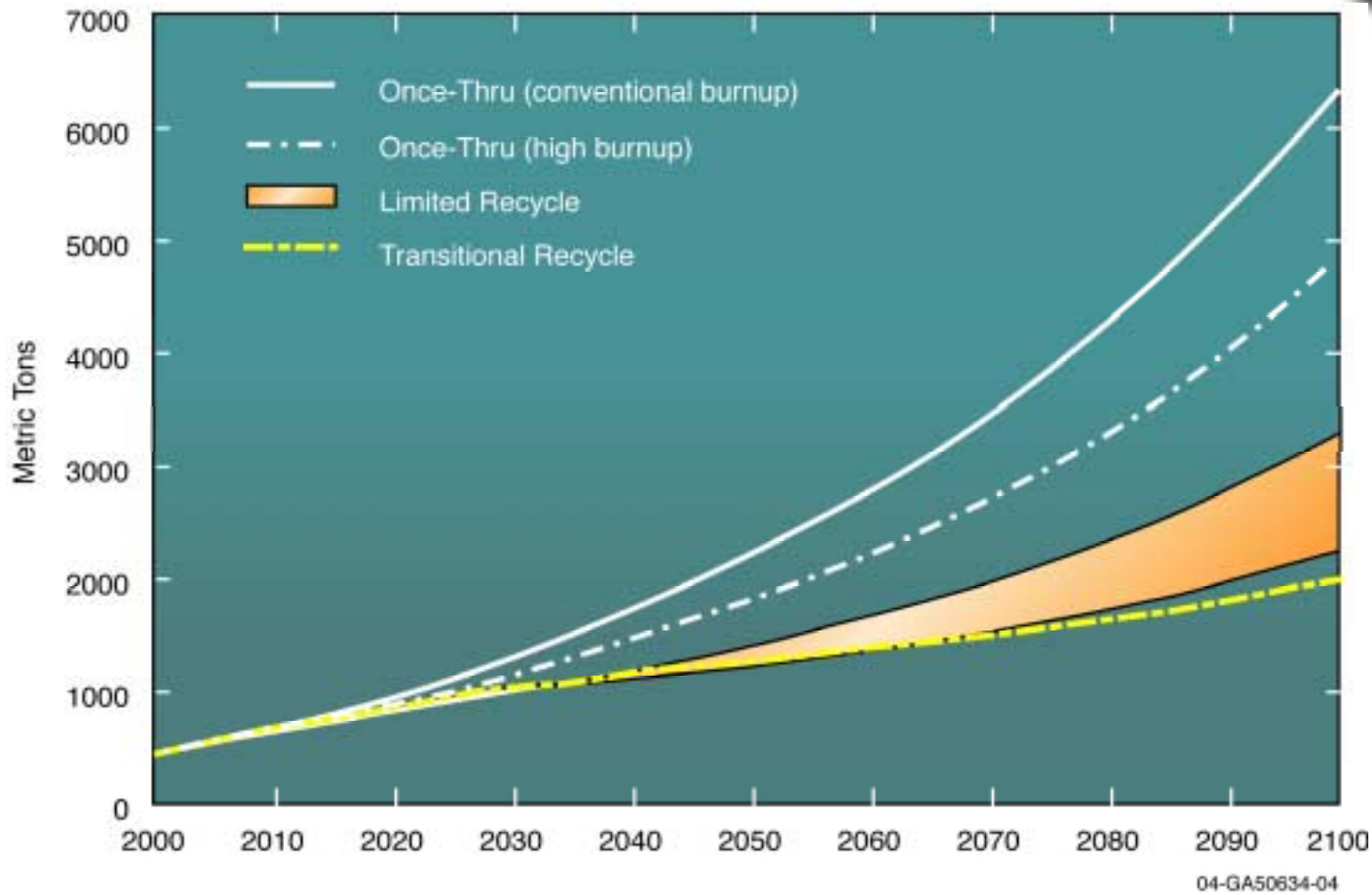

# Impact of FR Deployment on Uranium Resource Needs

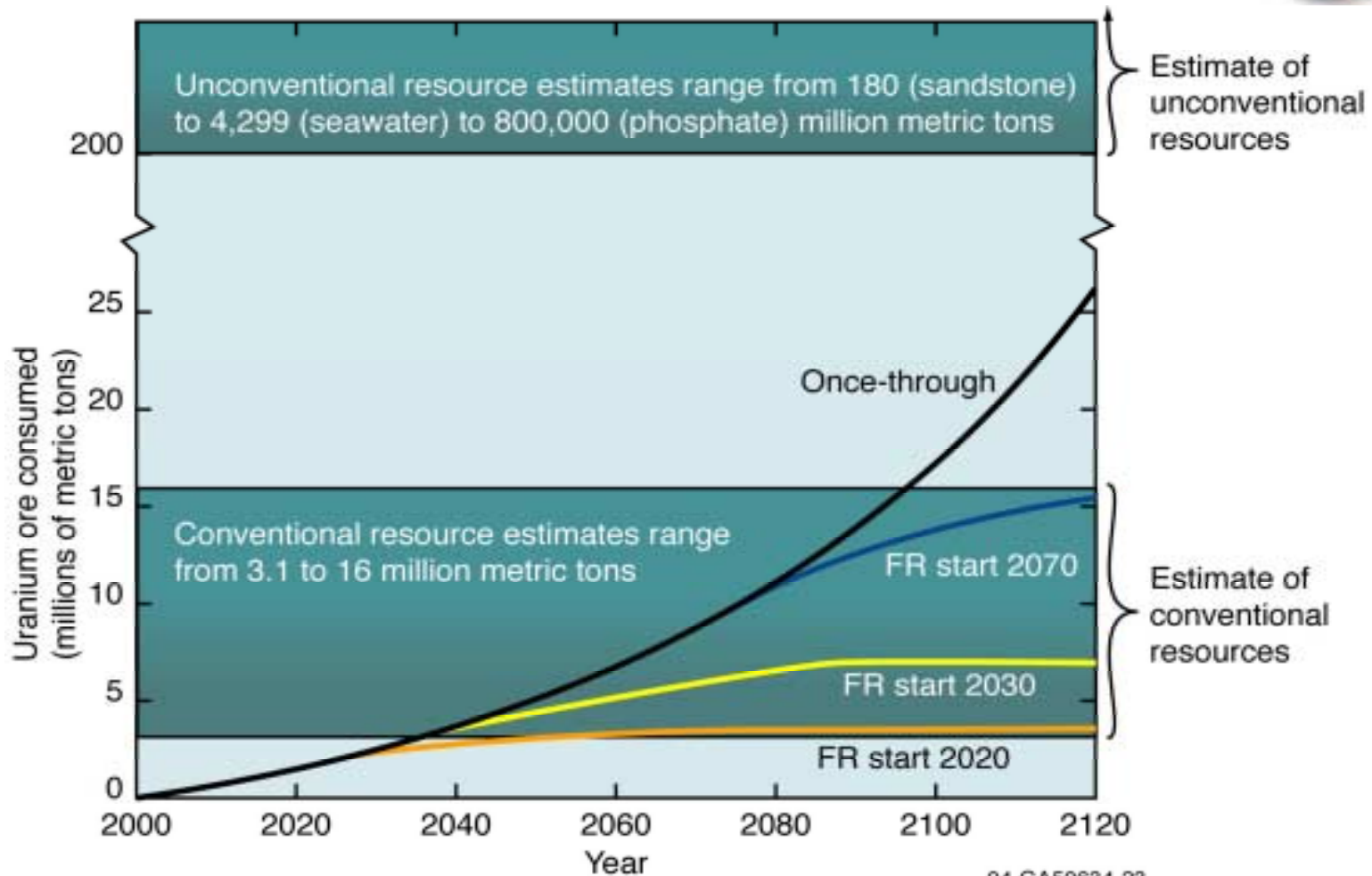

04-GA50634-23

# Transmutation System Approaches

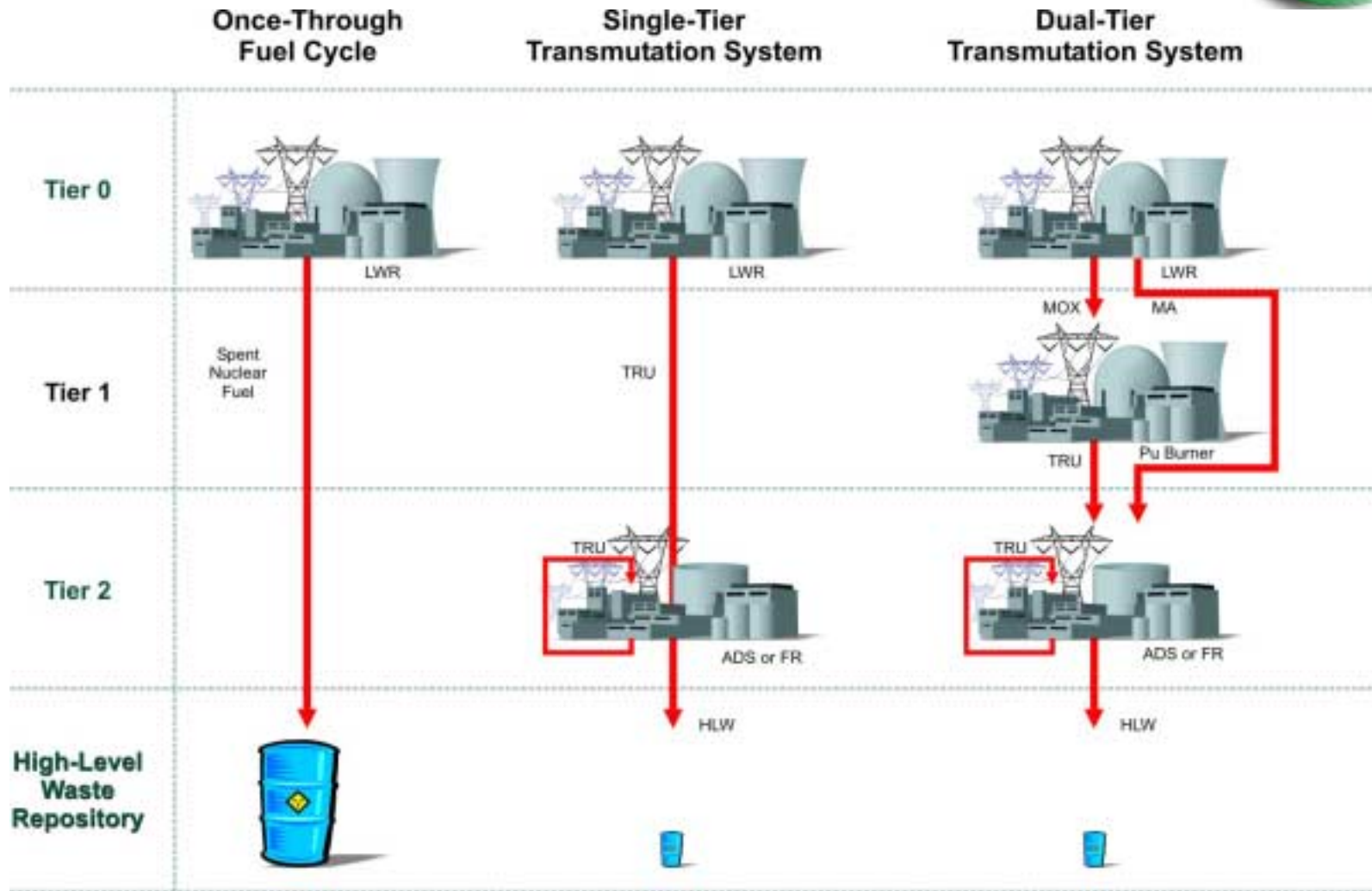

# GNEP Deployment Systems Requirements



- *The system must result in a significant improvement in repository utilization, preferably avoiding the need for a second geologic repository this century*
- *The system must optimize waste management including minimizing waste that needs to be handled or stored, and producing only solid waste with robust waste forms*
- *The system must make available the energy value of separated materials for future use*
- *The system must reduce proliferation risk*
- *The system must be deployable in a timeframe so as to reassert U.S. leadership, and influence fuel cycle development worldwide (20 years)*
- *The system must remain as economical as possible*
- *The system must be environmentally sound*

# GNEP Deployment System

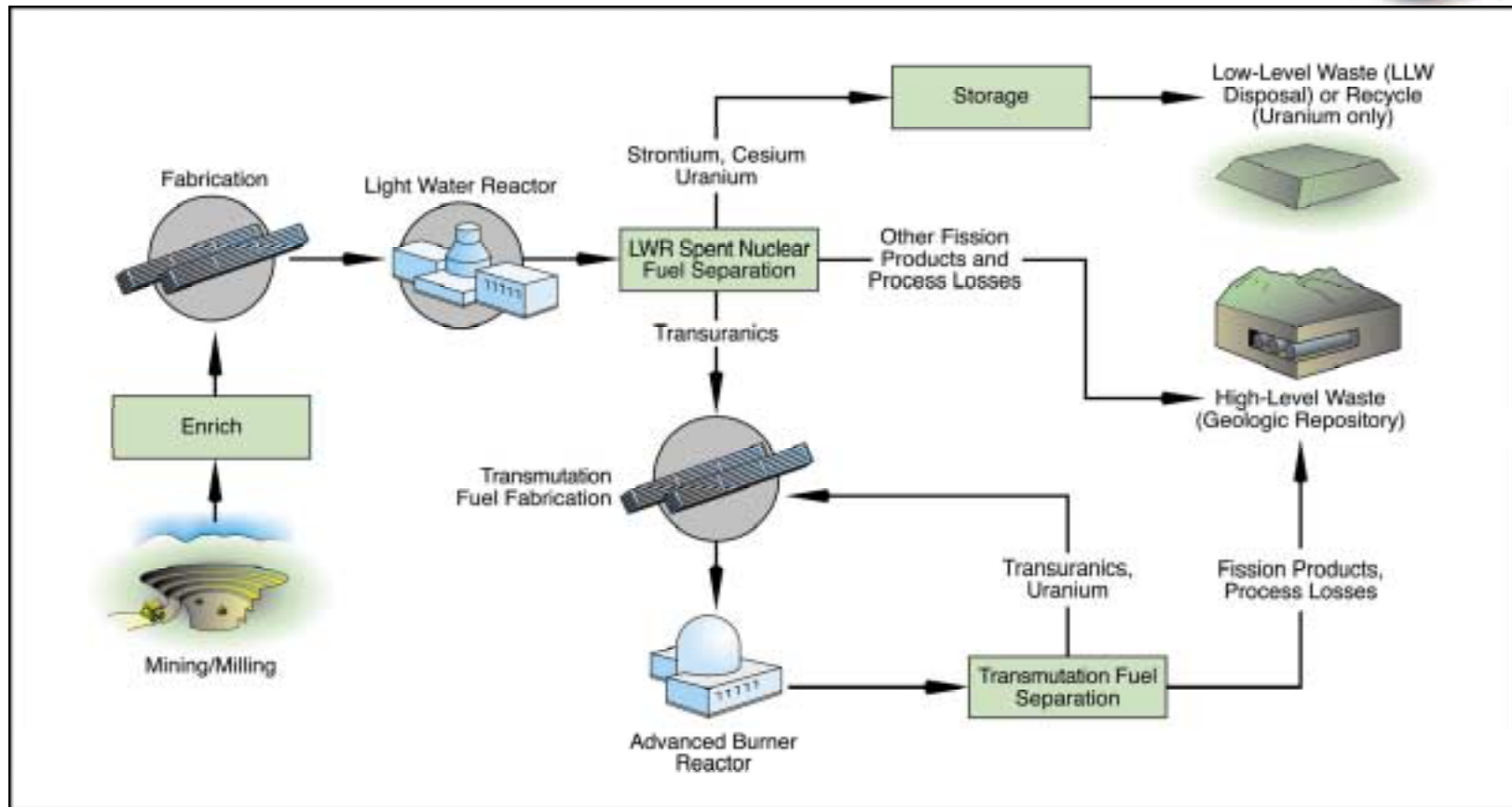

# Global Nuclear Energy Partnership Technology Demonstration (GNEP-TD)



- *GNEP Technology Demonstration Program*
  - *Focus on domestic demonstration of key technologies*
  - *International partnerships in technology development*
  - *Embedded university program*
  
- *5-year technology plan under development*
  - *10 labs involved*
  
- *Provision of intellectual basis for GNEP-TD decisions*
  - *Basis studies*



# ***Technology Demonstration Program Approach***

- *Systems Integration*
- *LWR Spent Nuclear Fuel Separation Technologies*
- *Transmutation Technologies*
- *Transmutation Fuels and Separations Technologies*
- *Modeling and Simulation*
- *International Safeguards and Proliferation Risk Reduction*

# GNEP Technology Demonstration Facilities

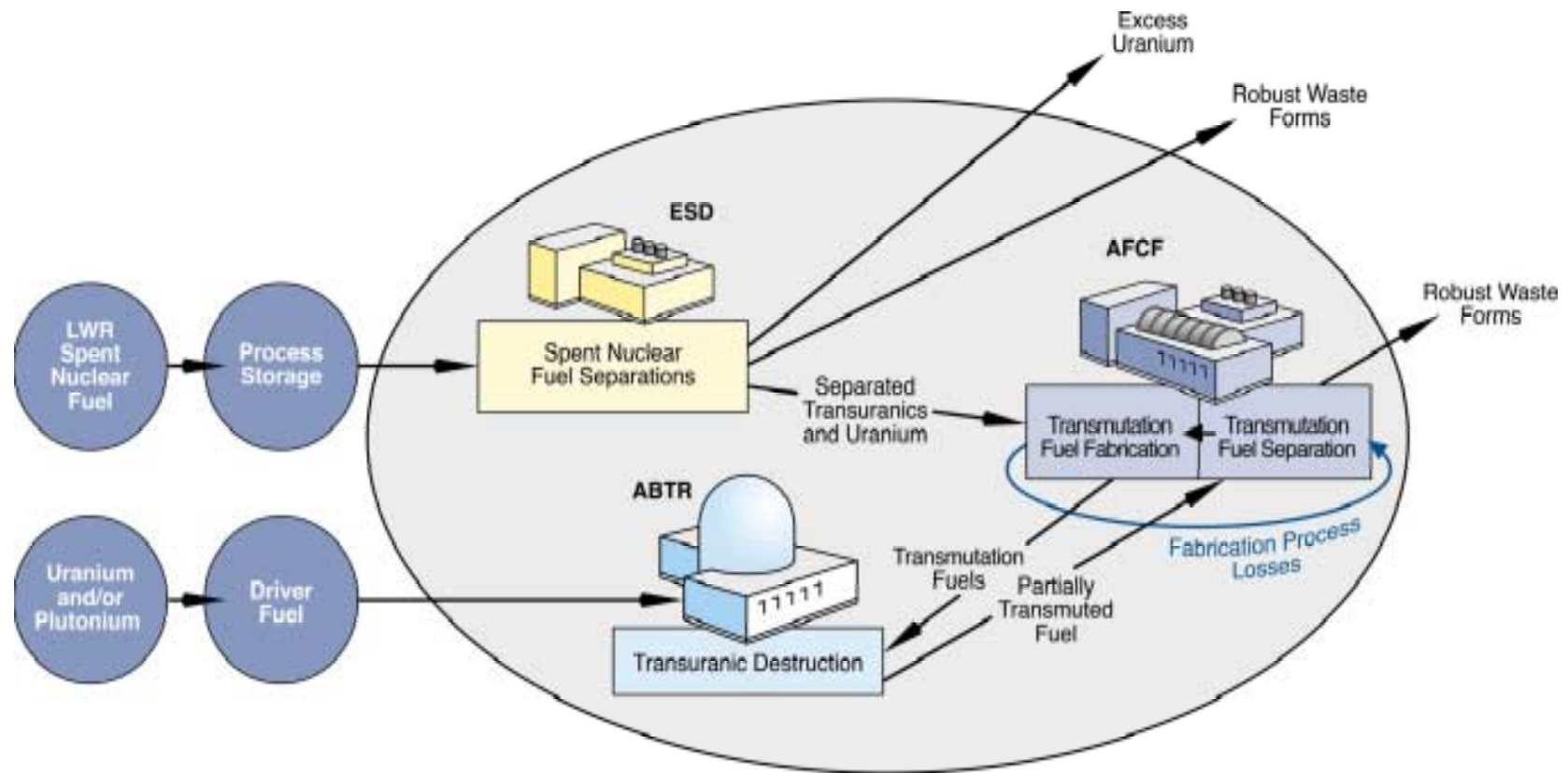



# GNEP-TD Facilities



## ■ **Engineering-Scale Demonstration (ESD)**

- *Demonstration of the UREX+1a process*
- *Source of supply of transuranic elements for Advanced Burner Test Reactor*
- *Suitable for process optimization*
- *Size is to be determined from performance requirements*

## ■ **Advanced Fuel Cycle Facility (AFCF)**

- *Demonstration of transmutation fuel fabrication and processing*
- *Modular research laboratory*
  - Aqueous separations demonstration at up to 25 metric tons per year
  - Pyrochemical separations demonstration at >1 metric ton per year
  - Recycle fuel fabrication development and demonstration
  - Supporting R&D laboratories

## ■ **Advanced Burner Test Reactor (ABTR)**

- *Demonstrate performance of transmutation fuel*
- *Size is to be determined from performance requirements*

# Suite of UREX+ Processes



<i>Process</i>	<i>Prod #1</i>	<i>Prod #2</i>	<i>Prod #3</i>	<i>Prod #4</i>	<i>Prod #5</i>	<i>Prod #6</i>	<i>Prod #7</i>
UREX+1	U	Tc	Cs/Sr	TRU+Ln	FP		
UREX+1a	U	Tc	Cs/Sr	TRU	All FP		
UREX+2	U	Tc	Cs/Sr	Pu+Np	Am+Cm+Ln	FP	
UREX+3	U	Tc	Cs/Sr	Pu+Np	Am+Cm	All FP	
UREX+4	U	Tc	Cs/Sr	Pu+Np	Am	Cm	All FP

Notes: (1) in all cases, iodine is removed as an off-gas from the dissolution process.  
 (2) processes are designed for the generation of no liquid high-level wastes

U: uranium (removed in order to reduce the mass and volume of high-level waste)  
 Tc: technetium (long-lived fission product, prime contributor to long-term dose at Yucca Mountain)  
 Cs/Sr: cesium and strontium (primary short-term heat generators; repository impact)  
 TRU: transuranic elements (Pu: plutonium, Np: neptunium, Am: americium, Cm: curium)  
 Ln: lanthanide (rare earth) fission products  
 FP: fission products other than cesium, strontium, technetium, iodine, and the lanthanides

## Advanced Fuel Cycle Facility (AFCF) main mission is to develop and demonstrate advanced fuel recycling technologies



- *Cost effective alternatives for high level nuclear waste management in the form of advanced closed fuel cycles.*
- *Advanced proliferation-resistant fuel recycling technologies including chemical processing and fuel fabrication.*
- *Advanced safeguards including advanced instrumentation for materials protection, control and accountability (MC&A), and advanced control and monitoring systems.*



# Advanced Burner Test Reactor: A Key Component of GNEP-TD



- *Thermal reactors only suited for limited transmutation*
- *The role of thermal reactors for transmutation in the US is strongly reduced by the policy that avoids separation of pure plutonium, and the lack of a specific US infrastructure*
- *Fast reactors can effectively destroy all transuranics*
  - *Proliferation issue*
  - *Waste issue*
- *GNEP-TD will focus on fast reactor recycling*
- *Major challenges*
  - *TRU fuels and reprocessing*
  - *Cost reduction*
  - *Demonstration of passive safety*

# GNEP-TD Key Milestones and Planning Dates



- *EIS Record of Decision (6/08)*
- *Secretarial Decision on proceeding with demonstration (6/08)*
- *ESD operational (2011-2015)*
- *ABTR operational (2014-2019)*
- *AFCF operational (2016-2019)*

*DATES PROVISIONAL—To be determined through Technology Development plan*

# *The Global Partnership is Under Development*



Countries Approached by U.S. to be possible Fuel Cycle States

Japan – active follow-up

France – active follow -up

Russia – active follow - up

United Kingdom (In midst of Government Energy Study)

China (Follow-up being arranged)

~ 40 Countries briefed at International Atomic Energy Agency

Science Attaches briefed in DC

Detailed Discussion with Canada, South Korea

**International Response Positive**

# Summary



- *The GNEP Technology Demonstration Program*
  - *LWR spent fuel separations*
  - *Transmutation*
  - *Transmutation fuel separations and fabrication*
- *Key challenges exist for each technology demonstration*
  - *Separations efficiencies*
  - *Acceptable costs for fast reactors*
  - *Transmutation fuels*
- *A successful GNEP Technology Demonstration Program will require the expertise at national laboratories, universities, and industry*
- *GNEP will develop and demonstrate technologies that enable the transition to a stable, long-term, environmentally, economically, and politically acceptable advanced fuel cycle*